

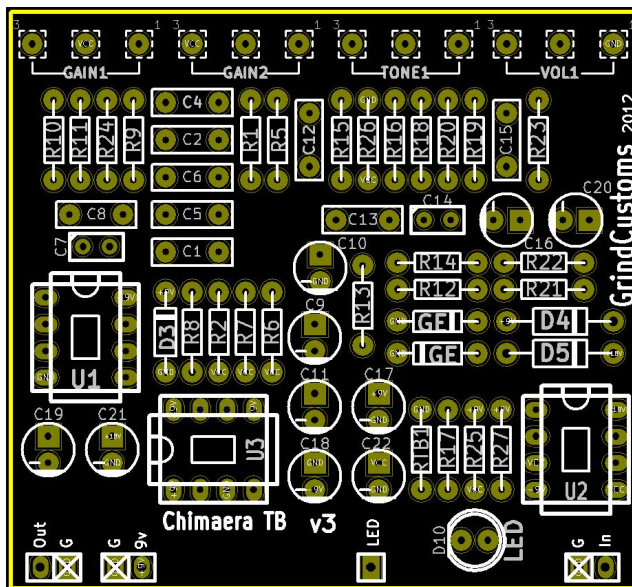

Chimaera - True Bypass



R1	10K	C1	100nf	GE	1N270/1N34A/BAT41
R2	1M	C2	100nf	GE	1N270/1N34A/BAT41
R3		C3		D3	1N4739 Zener 9.1V
R4		C4	68nf	D4	1N4001
R5	5.1K	C5	390nf	D5	1N4001
R6	1.5K	C6	68nf	D10	LED
R7	1K	C7	390pf		
R8	10K	C8	82nf	U1	TL072
R9	2K	C9	1uf	U2	TL072
R10	15K	C10	1uf	U3	TC7660SCPA/ICL7660SCPA/ MAX1044 (charge pump)
R11	422K	C11	1uf (Tantalum)		
R12	1K	C12	2.2nf	GAIN 1/2	B100K Dual Gang
R13	1.5K	C13	27nf	TONE	B10K
R14	15K	C14	820pf	VOLUME	B10K
R15	47K	C15	3.9nf		
R16	22K	C16	4.7uf		
R17	27K	C17	47uf		
R18	12K	C18	1uf		
R19	392K	C19	1uf		
R20	1.8K	C20	1uf		
R21	100K	C21	1uf		
R22	100K	C22	47uf		
R23	4.7K				
R24	560R				
R25	27K				
R26	27K				
R27	3.9K				
RTB1	2.2M				



Overview

All of the unicorn tears, none of the wait list!!

Build Notes

- Refer to the PCB image below for reference when populating or troubleshooting your build.
- On the schematic (page 3), C7 and C8 have the right value, but the names are inverted
- Not all ground pads need to be used, they're only there for wiring convenience.

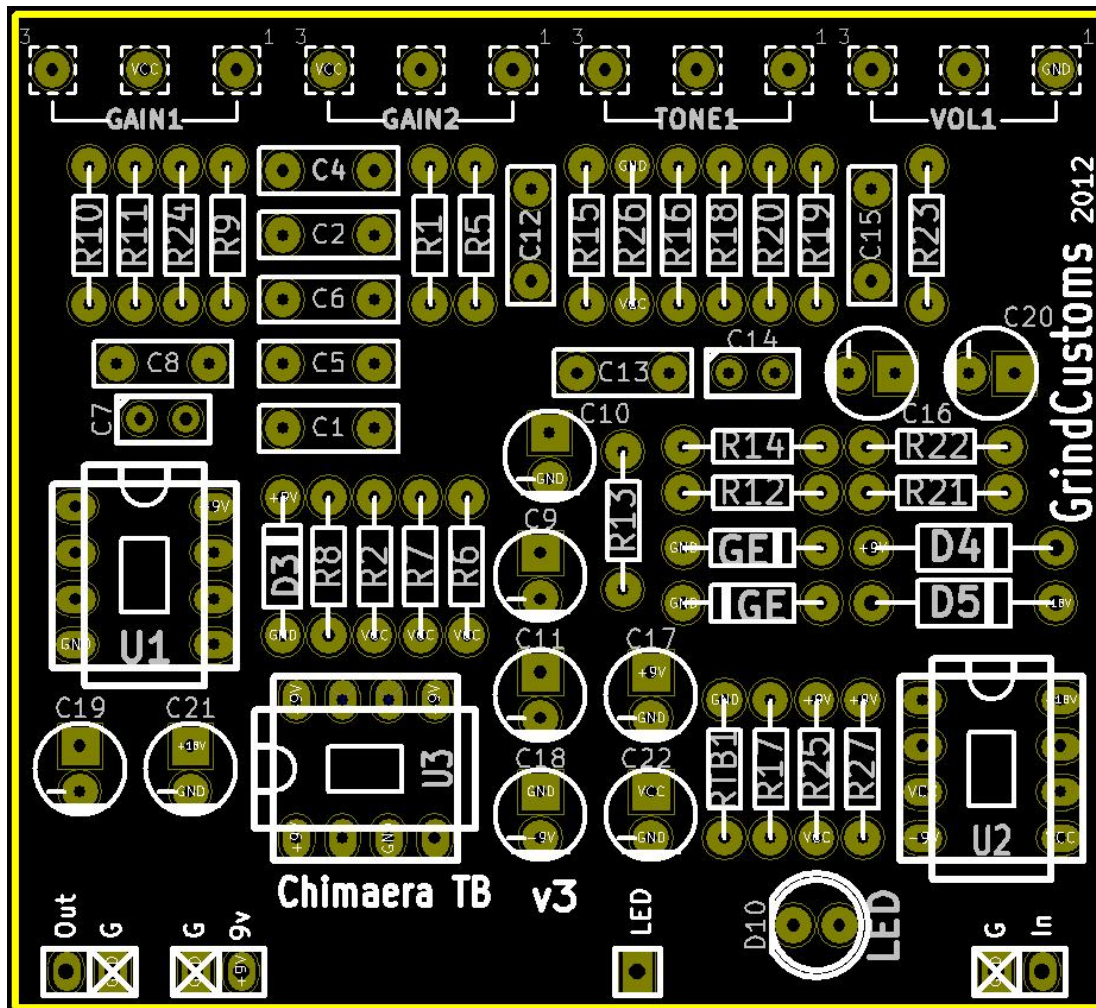

GRIND CUSTOMS FX

www.grindcustomsfx.com

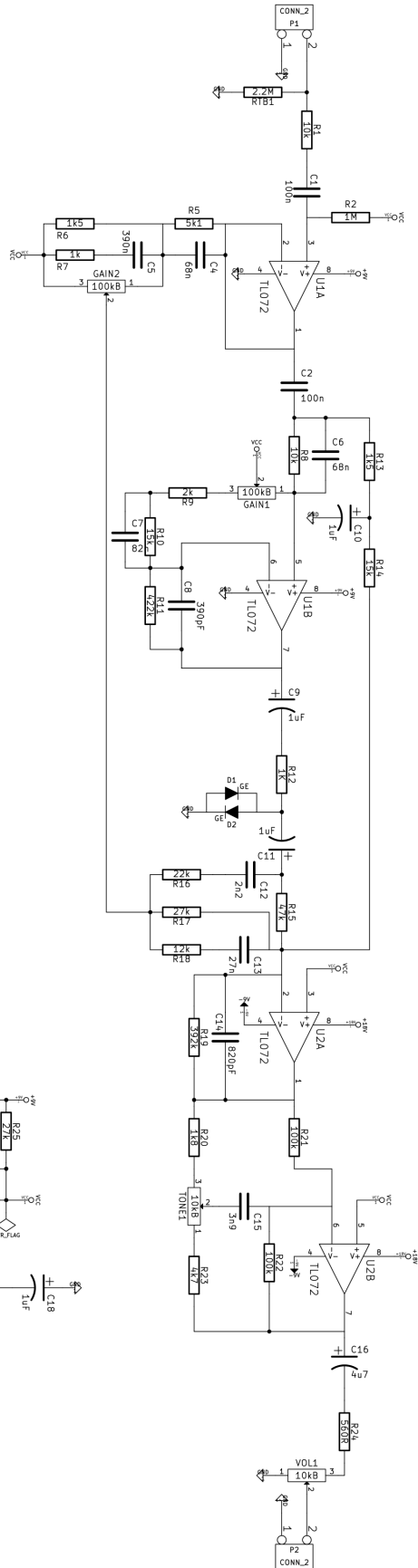

True Bypass Version	
Grindcustoms	
File: Chimera FB.sch	
Sheet: /	
Title: Chimera BFD	Rev: 3
Size: B	Date: 29 oct 2012
KICad E.D.A. _ eschema (2012-01-19 BZR 3256) - stable	id: 1/1

